



Nominal data

Type	4414 FNH	
Nominal voltage	VDC	24
Nominal voltage range	VDC	18 .. 26.4
Speed (rpm)	min ⁻¹	5400
Power consumption	W	12
Min. ambient temperature	°C	-20
Max. ambient temperature	°C	70
Air flow	m ³ /h	225
Sound power level	B	6.7
Sound pressure level	dB(A)	55

ml = Max. load · me = Max. efficiency · fa = Free air · cs = Customer specification · ce = Customer equipment
Subject to change

Technical description

Housing material	Glass-fiber reinforced PBT plastic
Impeller material	Glass-fiber reinforced PA plastic
Weight	0.240 kg
Dimensions	119 x 119 x 25 mm
Airflow direction	Exhaust over struts
Direction of rotation	Counterclockwise, viewed toward rotor
Storage	Ball bearing
Service life L10 at 40 °C	60000 h
Service life L10 at maximum temperature	30000 h
Cable	Leads AWG 22, TR 64, stripped and tin-plated.
Motor protection	Protection against reverse polarity and blocked rotor.
Option	Vario-Pro

Product drawing

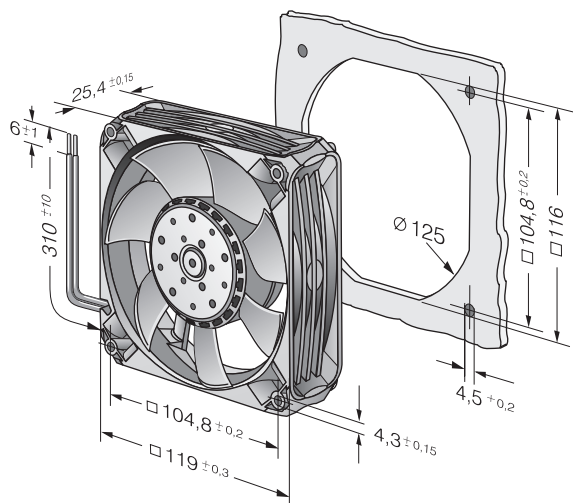

Curves: Air performance

